

### 线材要求

- A: 12V电源线： 2×0.75mm<sup>2</sup> 或 2×1.0mm<sup>2</sup> ；
- B: 信号控制线： RVVP 2×0.75mm<sup>2</sup> 双绞屏蔽线；
- C: 模式切换线： 2×0.5mm<sup>2</sup> ；
- D: 楼层控制线： 每个楼层按钮需要2芯，1根网线支持4个楼层按钮；（建议采用0.5的8芯双屏网线）；  
如：8层楼，则需要16根控制线，所以需要2根8芯的网线。每根的长度在4米左右。

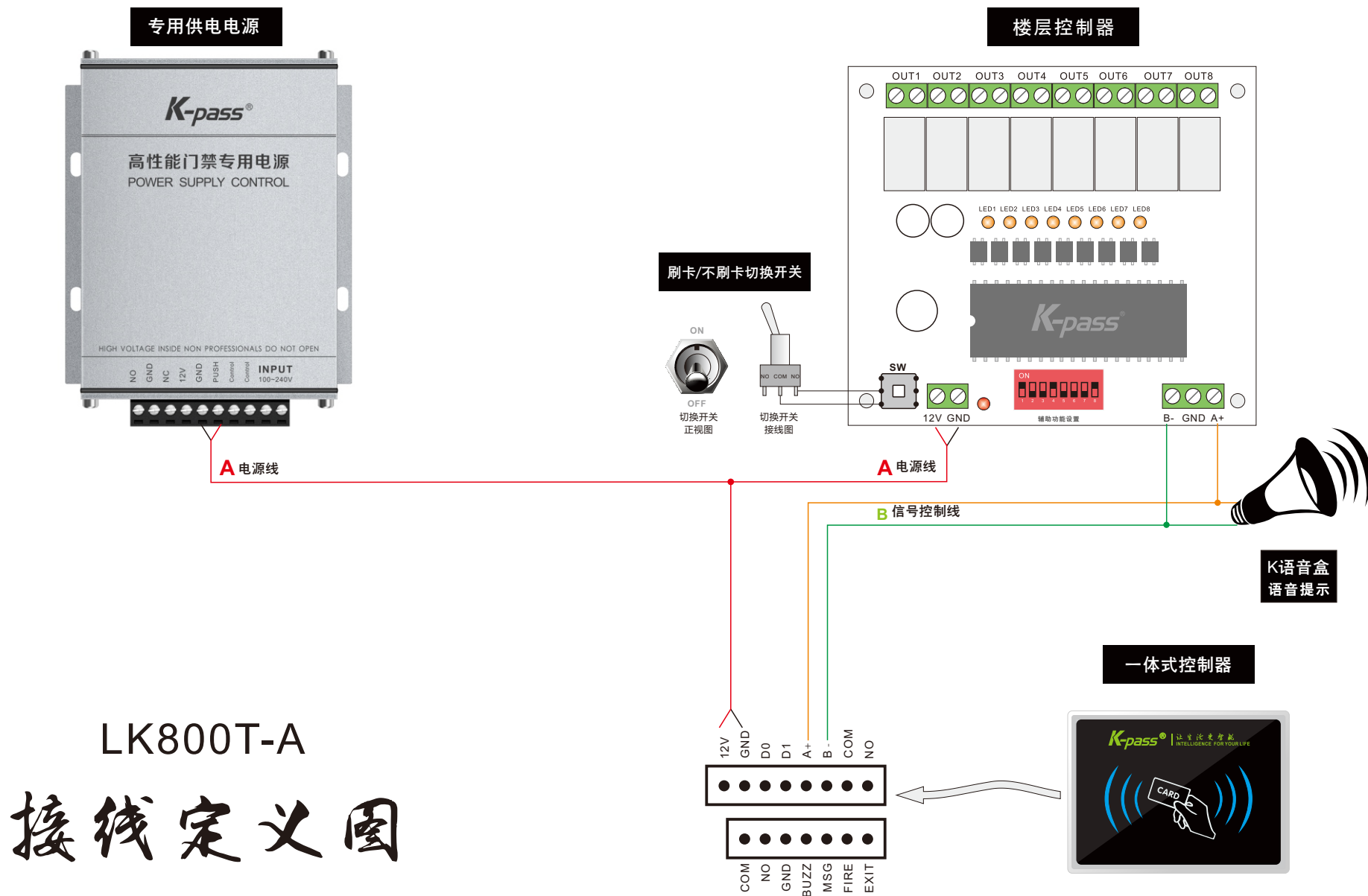



LK800T-A

### 接线定义图



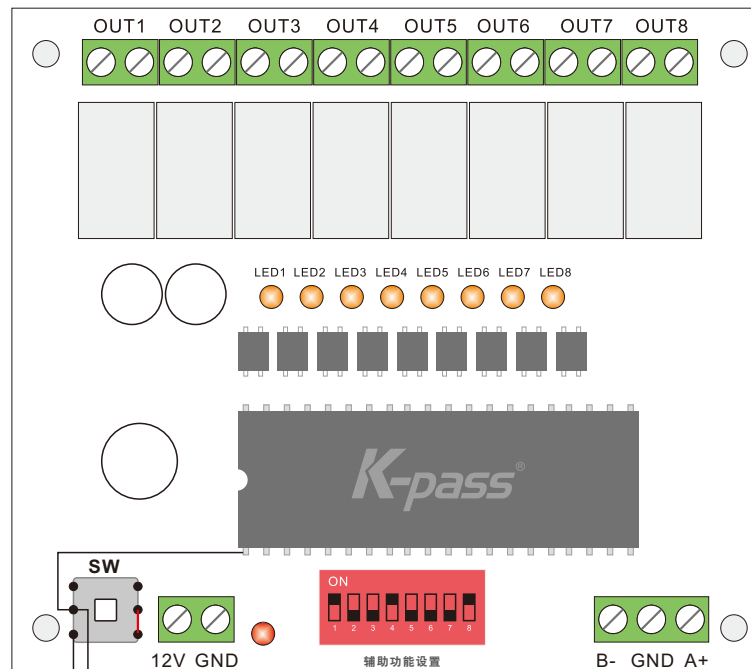

刷卡/不刷卡切换开关

LK800T-A

# 接线定义图

